



Application: Suitable for large halls, greenhouses, pig farms, warehouses, industrial installations, parkings etc.

Axial Fans W Series 900 RPM

- Excellent quality axial fans with frame.
- High quality 6 pole motor with bearings from the German Factory ebm-papst.
- IP 44, IP 54.
- Class F, B.
- Thermal protection: All motors are fitted with internal thermal protection (Klixon) to avoid overheating.
- Fans include protection guard.
- Speed controllable.
- Aluminum or plastic gravity Grills available for all fan models.

W6E Series 900 RPM 230 V

Type	Ø (mm)	Power (W)	Air flow (m³/h)	RPM	Amperage (A)	Price
W6E - 630	630	600	11.020	925	2.04	€ 625,00

W6E Series 900 RPM 400 V

Type	Ø (mm)	Power (W)	Air flow (m³/h)	RPM	Amperage (A)	Price
W6D - 630	350	600	11.270	930	1,07	€ 625,00
W6D - 710	710	840	14.430	935	1,45	€ 1.050,00
W6D - 800	800	1.940	24.110	925	3,30	€ 1.089,00
W6D - 910	910	2.480	32.100	930	4,38	€ 1.705,00

Frame Dimensions

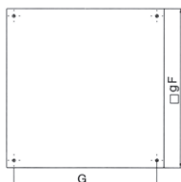

Ø (mm)	qF (mm)	G (mm)
630	805	750
710	850	810
800	970	910
910	1070	1010

- Airflow direction from motor to impeller (blowing).

On request:

- Airflow direction from impeller to motor (sucking).
- With energy-saving motor. This especially applies to devices with a high duty cycle, such as air-conditioning and refrigeration systems.
- Contact our technical department for more information .

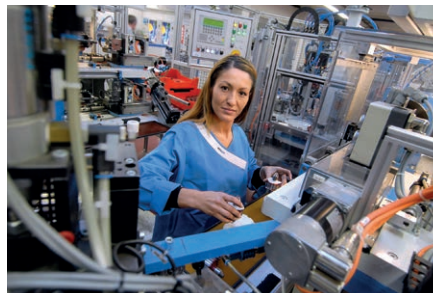

Accessories



AK 20 speed controller



400V Input Voltage Inverter



VK Series gravity grilles

Dimensions W6 Series

W6 630

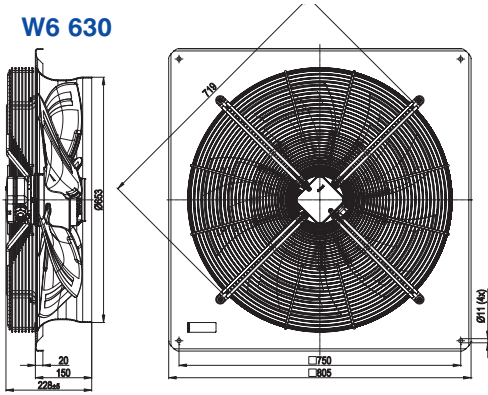

W6D 710

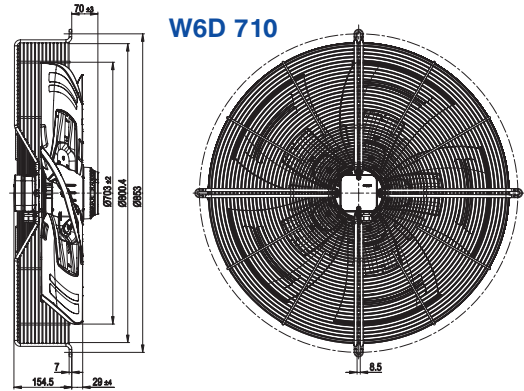

W6D 800

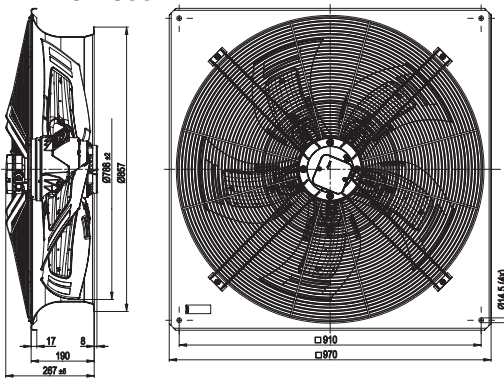

W6D 910

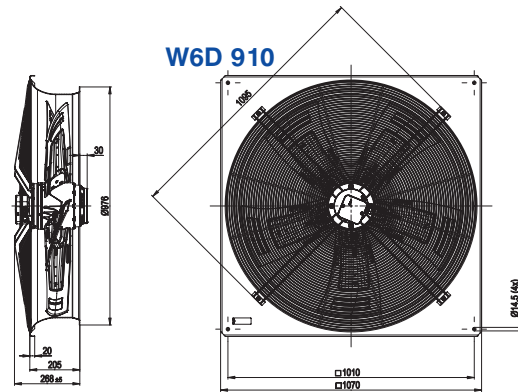

W6 900 RPM Performance Curves

